

EPC-T153

User Manual

Released Date:

November 16, 2022

version 2

Safety Precautions & Important Notices

Follow the messages below to avoid your systems from damage:

- Avoid static electricity from your system on all occasions.
- To prevent electric shock. Don't touch any components of this industrial PC when it is powered-on. Always disconnect power when the system is not in use.
- Disconnect power when you change any hardware devices. For instance, when you connect a jumper or install any memory, a surge of power may damage the electronic components or the whole system.
- Do not place the Industrial PC on an unstable surface.
- Unplug the power cable when thunderstorm weather with lightning occurs.
- Do not contact with or be exposed to inappropriate temperature, solvents, acid, water or moisture.
- Do not repair this product with an unauthorized agency or person.

After Sale Warranty Regulations

When handling a malfunctional product users should follow the principle of solving the problems. If possible, we may try to solve the problems via e-mail or telephone. If some problems can be solved via installing the specified update software or replacing the hardware by yourself, we will guide you how to obtain, install or replace it.

Within the warranty period, we will repair it under normal use. The manufacturer warranty is void under the following conditions:

1. Any fault or damage cause by abnormal use, accidents, refitting, improper physical or operating environment, nature disaster, surging and improper maintenance or storage.
2. Contact or exposed to unsuitable temperature, solvent, acid-base, water or moist environment.
3. Malfunction or damage after using the product, service or actions from the third party.
4. Malfunction or damage caused by using the illegal unauthorized, nonstandard or nonpublic issuing software.
5. Malfunction or damage caused by the force or accident drop to the floor or table.

Overview of Industrial Panel PC

Industrial Panel PC is designed for industrial application. It can be panel-mounted or wall-mounted. It can be widely used in many industrial fields, such as military, telecom, power traffic, railway, communication, finance, internet, medical treatment, security systems, industrial auto equipment etc.

Product Specifications:

Mechanical	Model Name	EPC-T153
	Display Type	15" TFT-LCD
	Max Resolution	1024 x 768
System	Processor	Intel® Core i3/i5/i7 CPU
	Chipset	Intel®
	Memory	DDR 4GB Max. 16GB
	SATA	1 x 2.5" SATA HDD Bay, mSATA
	Luminance/ Color	400cd/m ² , 16.7m 1000nits optional
Input / Output	USB Port	4 x USB
	Ethernet	2 x GbE LAN RJ-45
	HDMI	1 x HDMI
	VGA	1 x VGA
	COM	3 x RS-232
	Audio	1 x Line out, 1 x Lin In.
	View Angle	H: 160° / V:160°
Power	Power Input	DC 12~30V
Environment	Operating Temperature	-10° to 60°C
	Storage Temperature	-20° to 60°C
	Wi-Fi / Bluetooth	(Options)
OS Support	Windows 10 Pro, Linux	
	Standard Color	Black
	Construction	Aluminum alloy bezel and chassis
	Mounting	Panel-mount, VESA 75x75mm / 100x100mm
	IP Rating	IP66 compliant front panel
	Dimensions	378mm(W) x 56mm(D) x 297mm(H)
	Weight	12 lbs.
	Certification	CE/FCC Class A

Dimensions:

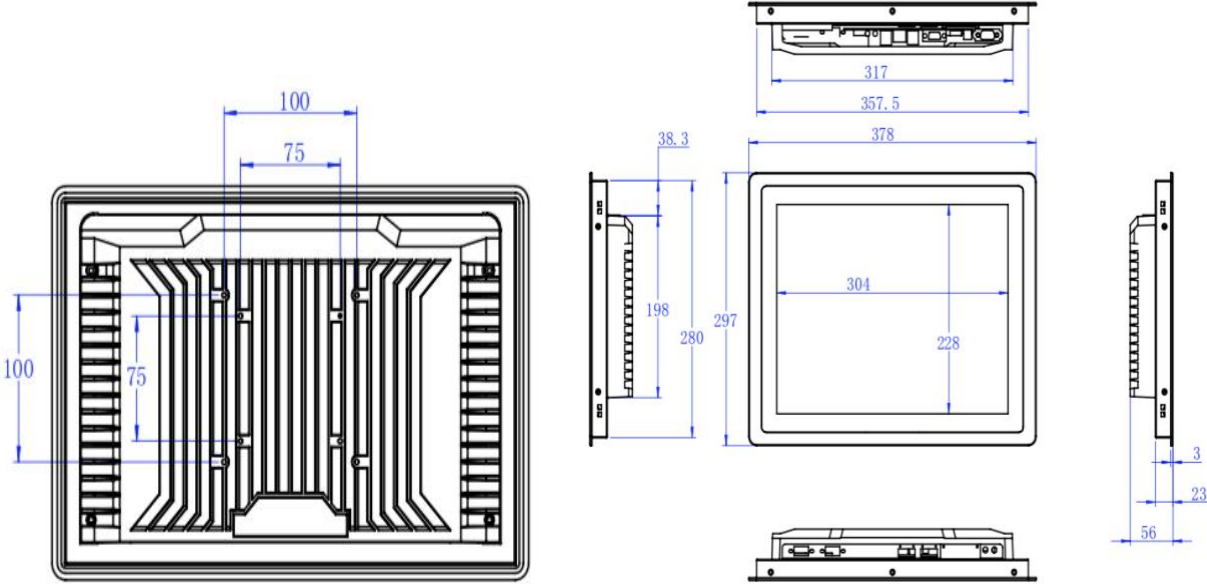

Installation of Industrial Panel PC

VESA-mount:

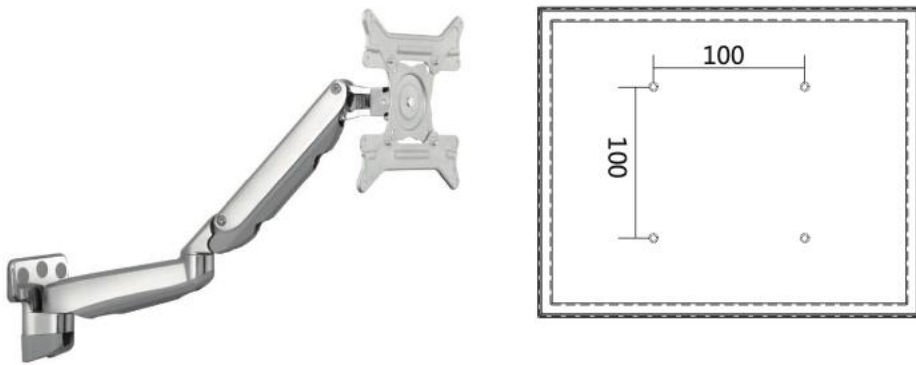

Panel-mount:

